

(No Model.)

3 Sheets—Sheet 1.

G. L. PALLATT.
BUTTON TURNING LATHE.

No. 256,588.

Patented Apr. 18, 1882.

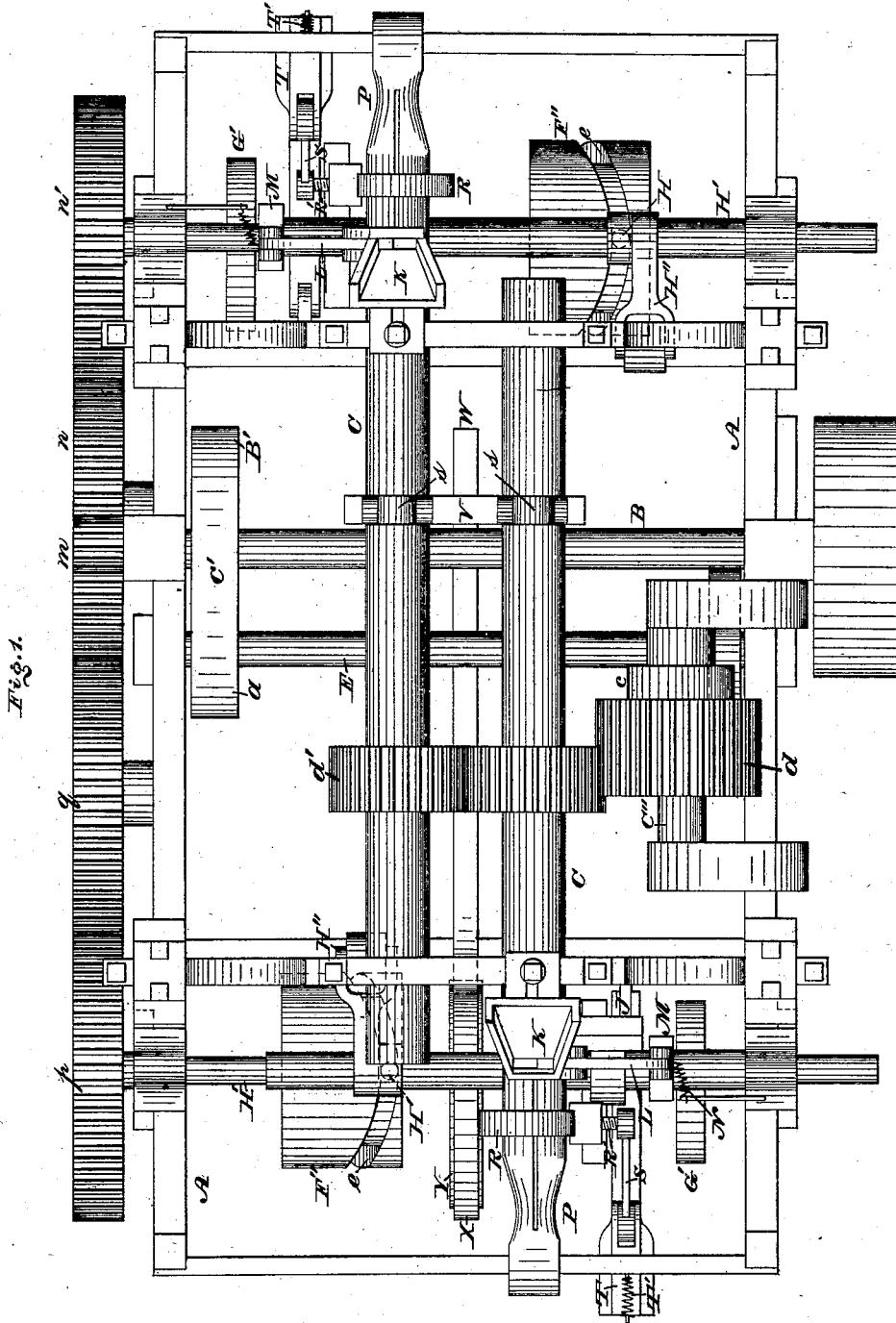

Fig. 1.

WITNESSES:

L. Douville
H. F. Fischer

INVENTOR:

George L. Pallatt,
BY: *John A. Diederheim*
ATTORNEY.

(No Model.)

3 Sheets—Sheet 2.

G. L. PALLATT.
BUTTON TURNING LATHE.

No. 256,588.

Patented Apr. 18, 1882.

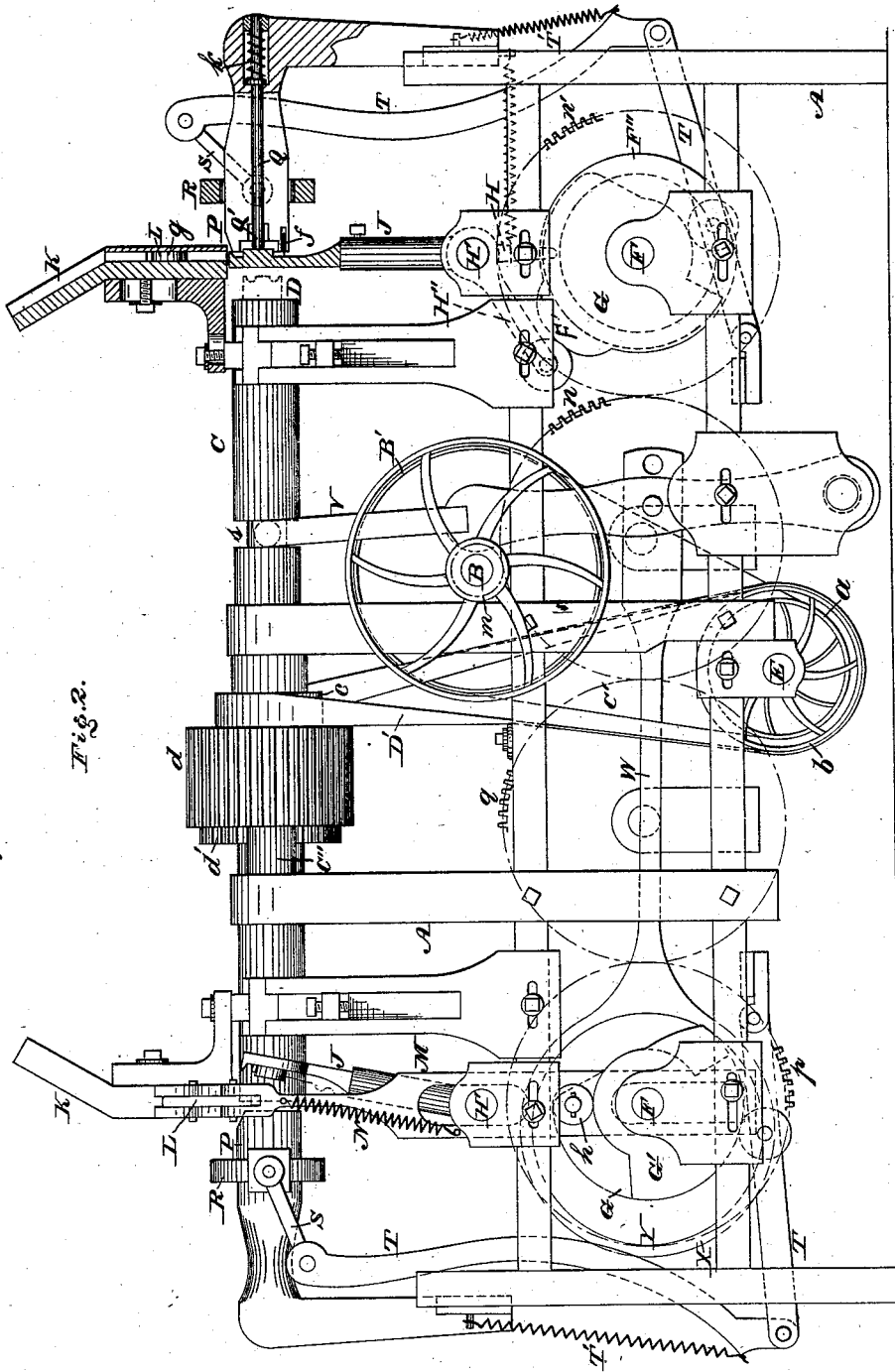

Fig. 2.

WITNESSES:

L. Dowille
W. F. Kircher

INVENTOR:

George L. Pallatt
John A. Diederheim

BY

ATTORNEY.

(No Model.)

3 Sheets—Sheet 3.

G. L. PALLATT.
BUTTON TURNING LATHE.

No. 256,588.

Patented Apr. 18, 1882.

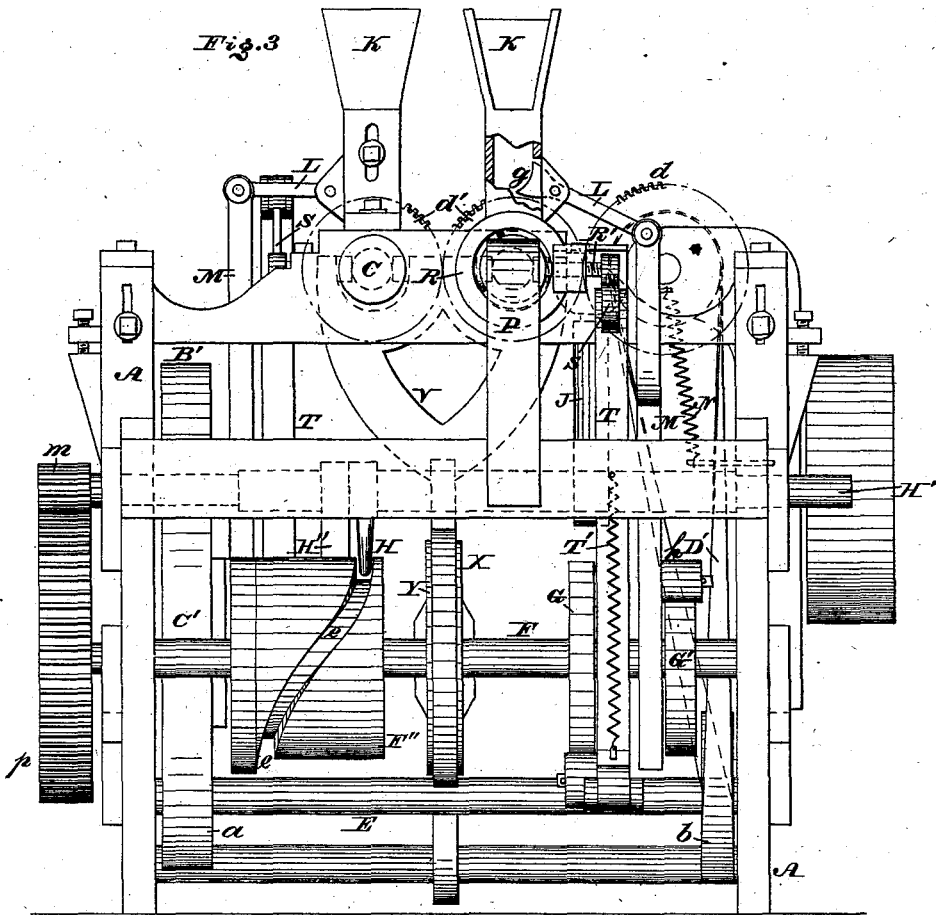

Fig. 4.

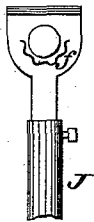

Fig. 5.

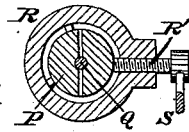

Fig. 6.



WITNESSES:
L. Douville
W. F. Kircher

INVENTOR:
George L. Pallatt,
 BY *John A. Dieckstein,*
 ATTORNEY

UNITED STATES PATENT OFFICE.

GEORGE L. PALLATT, OF PHILADELPHIA, PENNSYLVANIA, ASSIGNOR OF
THREE-FOURTHS TO OSTHEIMER BROTHERS AND WILLIAM T. PALLATT,
ALL OF SAME PLACE.

BUTTON-TURNING LATHE.

SPECIFICATION forming part of Letters Patent No. 256,588, dated April 18, 1882.

Application filed July 22, 1881. (No model.)

To all whom it may concern:

Be it known that I, GEORGE L. PALLATT, a citizen of the United States, residing in the city and county of Philadelphia, State of Pennsylvania, have invented a new and useful Improvement in a Machine for Shaping, Cutting, Polishing, and Finishing Buttons and other Articles, which improvement is fully set forth in the following specification and accompanying drawings, in which—

Figure 1 is a top or plan view of the machine embodying my invention. Fig. 2 is a side view, partly sectional. Fig. 3 is an end view thereof. Figs. 4, 5, and 6 are views of detached parts.

Similar letters of reference indicate corresponding parts in the several figures.

My invention has for its object the shaping, cutting, polishing, and finishing of buttons and other articles.

It consists of means for feeding and holding the articles, in combination with two or more tool-carrying shafts provided with mechanism whereby both rotary and longitudinal reciprocating motions are imparted to said shaft, so that as one shaft is advanced the other is returned, and thus work is alternately performed at opposite ends of the machine.

It also consists of a chamber provided with a piece for feeding the article uniformly and properly to the carrier which conveys it to the chuck or holder.

It also consists of a carrier which receives the article, then conveys it to and lodges it in or on the chuck, and afterward retires, so that the tool may act on the article.

It also consists of an expansible chuck or holder and means for closing the same.

It also consists in providing the chuck or holder with a throw-off for the article after it has been shaped, finished, &c.

Referring to the drawings, A represents the frame of the machine, and B the driving-shaft mounted horizontally thereon.

C represents parallel shafts, which are mounted horizontally on the upper portion of the frame A, and each carries at one end a shaping, cutting, polishing, or finishing tool, D. The shafts are geared to each other and re-

ceive motion as follows: On the driving-shaft is secured a band-wheel, B', which by means of the belt or band C' communicates motion to the pulley a of a transverse shaft, E, which latter is mounted on the lower part of the frame and carries a pulley, b, around which passes a belt or band, D', which latter also passes around a pulley, c, whose shaft C'' is mounted on the frame A and carries a wide gear-wheel, d, which meshes with the gear-wheels d' of one of the tool-carrying shafts C; but the band D' may receive power from a pulley overhead or otherwise located.

F represents a horizontal shaft, which extends transversely and carries a cam, F', a cam-grooved pulley, F'', a cam, G, and a cam, G'.

Projecting in the cam-groove e of the pulley F'' is a foot or lug, H, secured to or formed with a sliding shaft, H', which extends transversely and is mounted on the frame A, and receives motion from said cam e.

To the shaft H' is also connected an arm, H'', which bears against the cam F', whereby rocking motions are imparted to said shaft H', these sliding and rocking motions being imparted to a carrier, J, for the button or other article to be shaped, cut, finished, &c. This carrier consists of an arm rising from the shaft H', firmly secured thereto, and has on its outer face a flange or other support, f, on which the article to be shaped, &c., is dropped and sustained. Above the carrier J is a supply spout or chamber, K, which is provided with a hopper or chute, and within said chamber is a feed-piece, L, which is pivoted to a proper portion of said chamber, and has a concave or depressed face, g.

Pivoted to the outer end of the feed-piece L is a sliding arm, M, which extends upright, and is properly mounted and carries a horizontal stud or roller, h, which rests against the face of the cam G', whereby by rotation of the shaft F and said cam G' the arm M is raised and lowered, thus imparting motion to the pivoted feed-piece L, the return or lowering motion of said arm being assisted by a spring, N, which is connected to a proper part of the arm M and the frame A.

P represents a chuck or holder for the arti-

cle to be shaped, finished, &c., the same being divided or split longitudinally and formed hollow to receive within it a throw-off shaft, Q, whose head Q' is at the inner end of the chuck, said shaft being forced inwardly by the action of a spring, k, which is connected to the shaft and chuck.

Surrounding the inner end of the chuck is a sleeve, R, through one side of which is passed a screw, R', whose point bears against one of the jaws or sections of the chuck P, the sleeve R being somewhat larger than the chuck, so as to allow play of the jaw or section of the chuck against which the screw R' is adapted to abut. The head or shank of said screw R' has secured to it an arm, S, to which is pivoted a jointed lever, T, which is engaged by the cam G, so that by the rotation of the cam the lever T is depressed and the screw R' is rotated in one direction. The return motion of the lever T may be assisted by a spring, T', which is secured to the frame A and a proper portion of said lever T, said return motion causing the rotation of the screw R' in the direction opposite to that previously occasioned. By these means the screw is respectively tightened against and released from the chuck, and the latter thus closed and permitted to open.

The supply-chamber K, feeding-piece L, carrier J, chuck P, throw-off Q, and the operating mechanism thereof, as hereinbefore described, exist at opposite ends of the frame A, each shaft F having the cams F' G' and cam-grooved pulley F''. One of the shafts receives power from the main or driving shaft B through the medium of a pinion, m, on said shaft and an idler, n, mounted on the frame A and meshing with said pinion m and a spur-wheel, n', on said shaft F. The other shaft F is provided with a spur-wheel, p, which meshes with an idler, q, which meshes with the idler n, so that both shafts F and connected mechanism are simultaneously operated. The two shafts C have longitudinal sliding motions on the frame A, and are so disposed that the tool of each shaft is in direct line with one of the chucks P, and so operated that when one shaft is advancing to its chuck the other shaft is receding from its chuck. Each shaft C has a neck, s, which is encircled freely by a yoke, V, whose arm or support is pivoted to the frame A, and has connected to it an arm, W, which is provided with a yoke, X, which encircles an eccentric, Y, of one of the shafts F, whereby by the rotation of said eccentric reciprocating motions are imparted to the yoke V and sliding motions are imparted to the two shafts C. It is evident that more than two shafts may be employed, and the other parts of the machine—viz., the supply, feed, carrier, &c.—require to be multiplied relatively to the number of shafts.

As has been stated, the tool of one shaft is advancing to its chuck and the tool of the other shaft is receding from its relative chuck. Consequently the two sets of feeding devices, carriers, chucks, screws, &c., are so disposed that

each set operates in harmony with the respective tool.

When power is applied to the shaft B the shafts C receive both rotary and reciprocating sliding motions and other parts of the machine are set in operation. The blanks of the buttons or other articles to be shaped, finished, &c., are placed upright in the supply-chamber K, and the bottom blank is held by the concave or depressed face of the piece L, at which time the lever T is at its lowermost position, whereby the screw R' exerts no pressure on the jaws of the chuck P, and the carrier J is removed from beneath the feed-chamber. The carrier now advances, and when it is underneath the feed-chamber the arm M of the feed-piece L rises, whereby the head of said piece lowers, thus releasing the blank and permitting it to fall on the flange or support f of the carrier. The carrier now advances to the chuck P and deposits the blank in the front opening of said chuck, thus also forcing back the throw-off Q. The arm M then rises and the screw R' is quickly rotated, thus closing the chuck and clamping the blank to the jaws of the chuck. As the flange or support f enters an opening in the face of the chuck larger than the opening which receives the blank, said flange is not clamped by the chuck. The carrier now withdraws from the chuck and then moves laterally therefrom. The shaft C advances and the tool thereof acts on the exposed face of the blank, and when the shaping, cutting, &c., are accomplished the shaft withdraws, after which the arm M lowers, thus rotating the screw R', whereby the chuck expands. The throw-off Q is then operative under the action of the spring k and forces the blank from the chuck, which blank drops and is caught or directed to a place of deposit. Meanwhile the feeding-piece L has its head raised, so that its concave or curved face g receives another blank. The carrier again advances, the feeding-piece lowers a blank and allows it to fall on the support f, the carrier inserts the blank in the chuck, and the other operations are repeated.

Having thus described my invention, what I claim as new, and desire to secure by Letters Patent, is—

1. The two rotating and sliding tool-carrying shafts, having necks s and geared together, and the gear-wheel d, in combination with forked yoke V, embracing both of said shafts, operating-arm W, and shaft F, substantially as set forth.

2. In a button-machine, a rock-shaft, H', in combination with a button-carrier secured thereto, and an operating-shaft, F, carrying cams, which give to said shaft H its longitudinal and rocking reciprocating motions, substantially as set forth.

3. In a button-machine, a sliding rock-shaft, H', having lug H and arm H², in combination with a button-carrier secured on said shaft, and operating-shaft F, provided with a cam which acts on said arm to rock shaft H', and with a cam-grooved pulley which acts on said lug to

slide said shaft H' longitudinally, substantially as set forth.

4. In a button-machine, the spout or chamber K and the feed-piece L, pivoted to and operating within said chamber, in combination with arm M, shaft F, cam G, and spring N, whereby the rotation of said shaft operates the said feed-piece, substantially as set forth.

5. In a button-machine, a chuck or button-holder, in combination with a carrier, J, a sliding rock-shaft, H', to which said carrier is secured, and a shaft and cams which give longitudinal and rocking reciprocating motions to said shaft H', substantially as set forth.

6. In a button-machine, the expansible chuck

or button-holder P, in combination with sleeve R, screw R', and a cam-shaft, F, and intermediate lever-connection for closing said chuck on the button, substantially as set forth.

7. In a button-machine, the split and hollow chuck or button-holder P, in combination with sleeve R, screw R', and the mechanism for rotating the same in opposite directions, and the loose spring-pressed throw-off Q, the latter being inclosed in the chuck, substantially as and for the purpose set forth.

GEORGE L. PALLATT.

Witnesses:

JOHN A. WIEDERSHEIM,
A. P. GRANT.